

Aesculap Endoscopic Technology

Challenger Ti

The next challenge - High technology in two dimensions



Do you want to experience the
Challenger Ti for the second time?



Do you want to load once, fire twelve
and be faster than ever before?

Therefore ...



Sie wollen den *Challenger Ti*
zum zweiten Mal erleben?

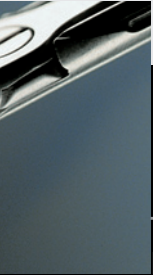

The reusable multi-fire clip applicator
Der resterilisierbare Clip-Applikator mit Multifire-Funktion

Challenger Ti



Sie wollen einmal laden, zwölfmal schließen
und sind schneller als je zuvor?

Dann ...

... we are offering you *two different clip applicators* with multi-fire function now.
Furthermore ...

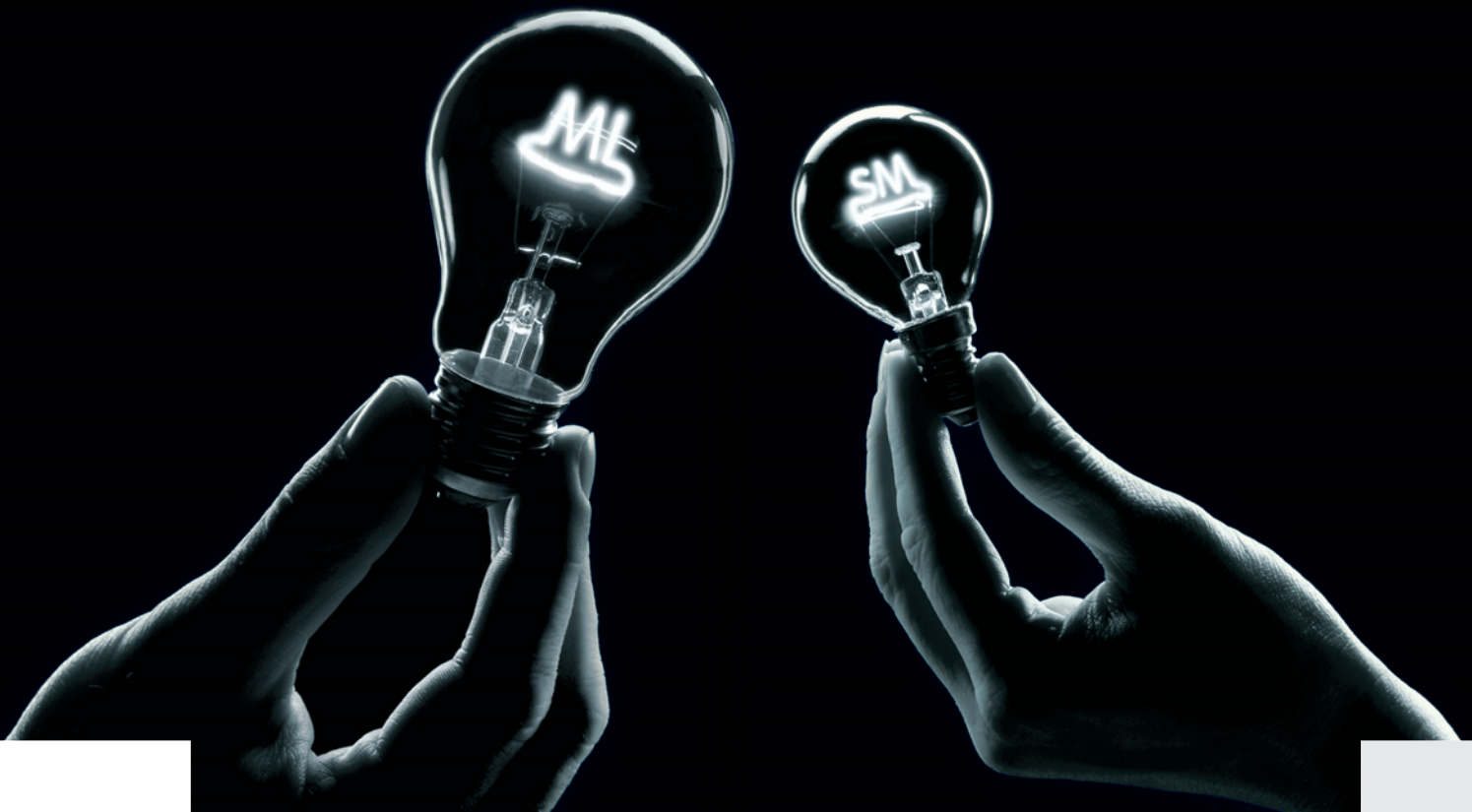

medium large

10 mm clip applicator / 10 mm Clip-Applikator



small medium

5 mm clip applicator / 5 mm Clip-Applikator

The following features of the AESCULAP clip applicators will convince you to take up our offer due to

- the modular design for easy and secure cleaning, maintenance and sterile preparation
- the simple disassembling of the parts
- easy and fast insertion of the sterile cartridge into the applicator
- separate functional elements for clip loading and clip closure
- stainless steel quality and precision



... bieten wir Ihnen jetzt *zwei unterschiedliche Clip-Applikatoren* mit Multifirefunktion.
Ausserdem ...



The reusable multi-fire clip applicator
Der resterilisierbare Clip-Applikator mit Multifire-Funktion

Challenger Ti

Beide AESCULAP Clip-Applikatoren überzeugen durch

- modulare Bauweise für einfache und sichere Aufbereitung, Pflege und Sterilbereitstellung
- ein einfaches Zerlegungsprinzip
- die Möglichkeit für einfaches und schnelles Einsetzen des sterilen Magazins
- separate Funktionselemente von Clip-Transport und Clip-Verschluss
- komfortables Handling durch eine einheitliche Griffform
- Präzision in Edelstahl

... we are offering you **two clip sizes** for most varied endoscopic procedures.

Standard 5:1, all measurements in mm
Maßstab 5:1, alle Maße in mm

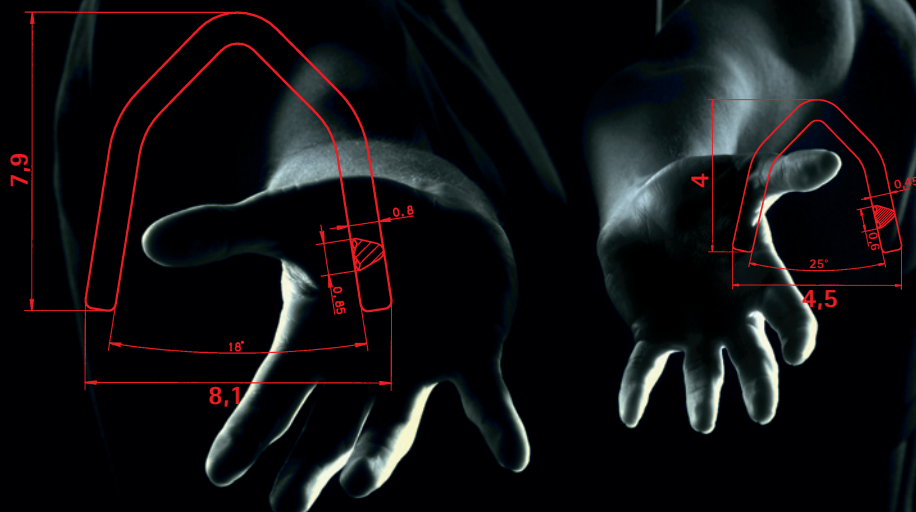

medium large

SMD
small medium

for 10 mm clip applicator / für 10 mm Clip-Applikator

for 5 mm clip applicator / für 5 mm Clip-Applikator

The following features of both clips will convince you to take up our offer due to

- the large contact area for safe clip application
- the closing action which protects against unwanted slipping effects of the tissue
- pure titanium for a better bio-compatibility



... bieten wir Ihnen jetzt *zwei Clip-Größen* für verschiedenste endoskopische Anwendungen.

The next challenge
High Tech in kleinsten Dimensionen

Challenger Ti

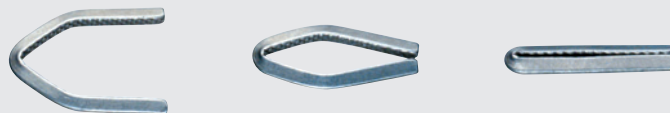

Beide Clips überzeugen durch

- große Clip-Kontaktfläche für sichere Applikation
- ihr Schließverhalten gegen ungewolltes Herausgleiten des Gewebes
- Reintitan für bessere Biokompatibilität

Order number
Bestellnummer

ChallengerTi

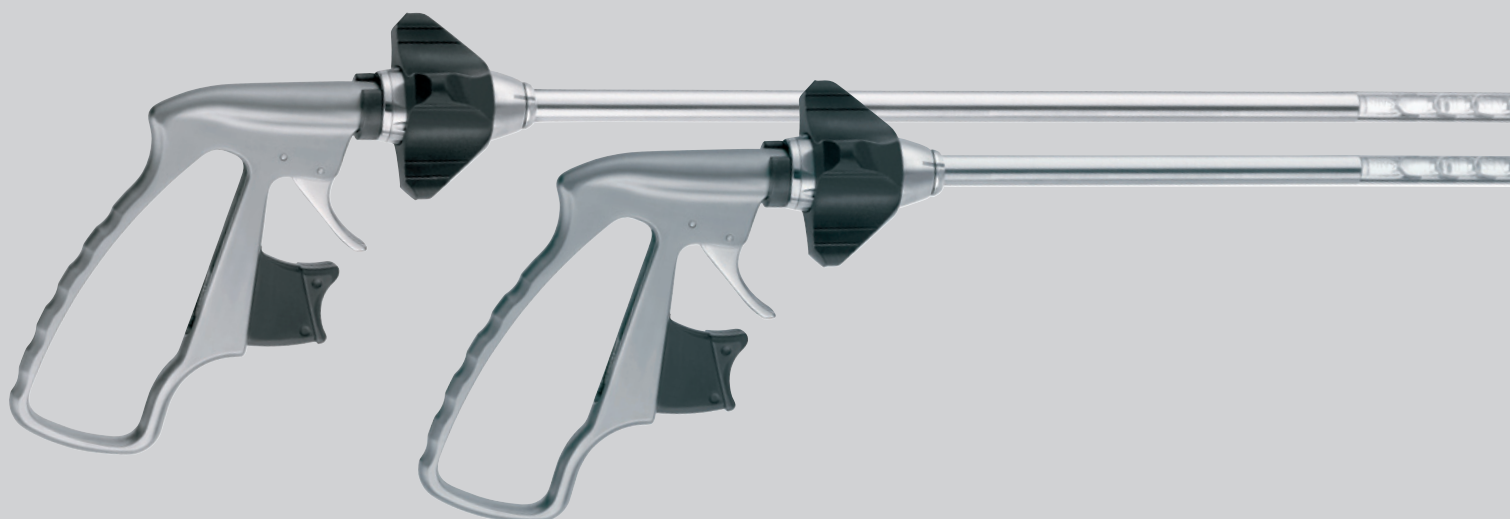



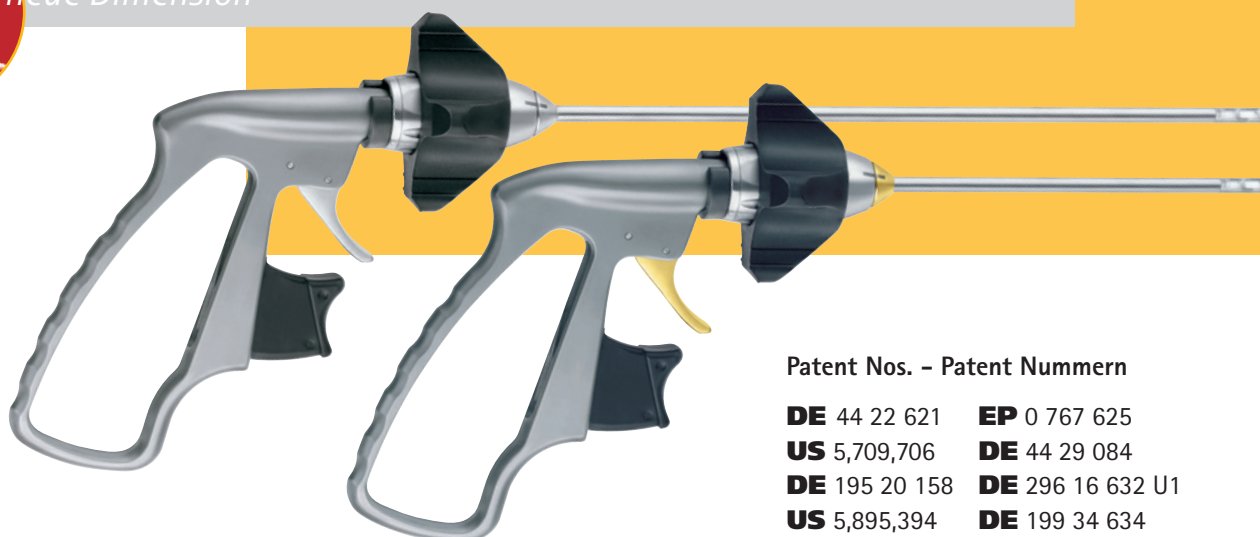





*The new dimension
Die neue Dimension*



Patent Nos. - Patent Nummern

DE 44 22 621	EP 0 767 625
US 5,709,706	DE 44 29 084
DE 195 20 158	DE 296 16 632 U1
US 5,895,394	DE 199 34 634



	ML	Clip applicator		ML	Clip-Applikator	
	PL506R	diam. 10 mm, working length 370 mm		Ø 10 mm, Arbeitslänge 370 mm		
	PL508R	diam. 10 mm, working length 260 mm		Ø 10 mm, Arbeitslänge 260 mm		
PL569T	Clip-Box	 1:1	with 12 sterile cartridges, of 8 titanium clips, last clip colour-coded	Clip box	 1:1	
		clip size: medium-large (ML)		mit 12 sterilen Magazinen, à 8 Titanclips, letzter Clip farbkodiert		
				Clipgröße: medium-large (ML)		
	SM	Clip applicator		SM	Clip-Applikator	
	PL512R	diam. 5 mm, working length 310 mm		Ø 5 mm, Arbeitslänge 310 mm		
	PL600R	diam. 5 mm, working length 205 mm		Ø 5 mm, Arbeitslänge 205 mm		
PL572T	Clip box	 1:1	with 12 sterile cartridges, of 12 titanium clips, last clip colour-coded	Clip-Box	 1:1	
		clip size: small-medium (SM)		mit 12 sterilen Magazinen, à 12 Titanclips, letzter Clip farbkodiert		
				Clipgröße: small-medium (SM)		

Spare Parts Reparatur- und Ersatzteile

■ Shaft/Schaft complete/komplett	PL536R	PL538R	PL522R	PL601R¹
	Shaft length/Schaftlänge 370 mm diameter/Durchmesser 10 mm	Shaft length/Schaftlänge 260 mm diameter/Durchmesser 10 mm	Shaft length/Schaftlänge 310 mm diameter/Durchmesser 5 mm	Shaft length/Schaftlänge 205 mm diameter/Durchmesser 5 mm
■ Inner tube/Innenrohr	PL536/802	PL538/802	PL522/801	PL601/801
	Shaft length/Schaftlänge 370 mm	Shaft length/Schaftlänge 260 mm	Shaft length/Schaftlänge 310 mm	Shaft length/Schaftlänge 205 mm
■ Push rod/Schubstange	PL536/801	PL538/801	PL522/800	PL601/800
	Shaft length/Schaftlänge 370 mm	Shaft length/Schaftlänge 260 mm	Shaft length/Schaftlänge 310 mm	Shaft length/Schaftlänge 205 mm
■ Handle/Griff	PL510R	PL510R	PL510 R	PL602 R²
■ Rotation knob/Drehstern	PL510/300	PL510/300	PL510/300	PL510/300
■ Safety ring/Sicherungsring C-ring/C-Ring	PL510/301	PL510/301	PL510/301	PL510/301

ML

SM

¹ not compatible with PL510R
nicht kompatibel mit PL510R

² not compatible with PL536R, PL538R, PL522R
nicht kompatibel mit PL536R, PL538R, PL522R



Challenger Ti

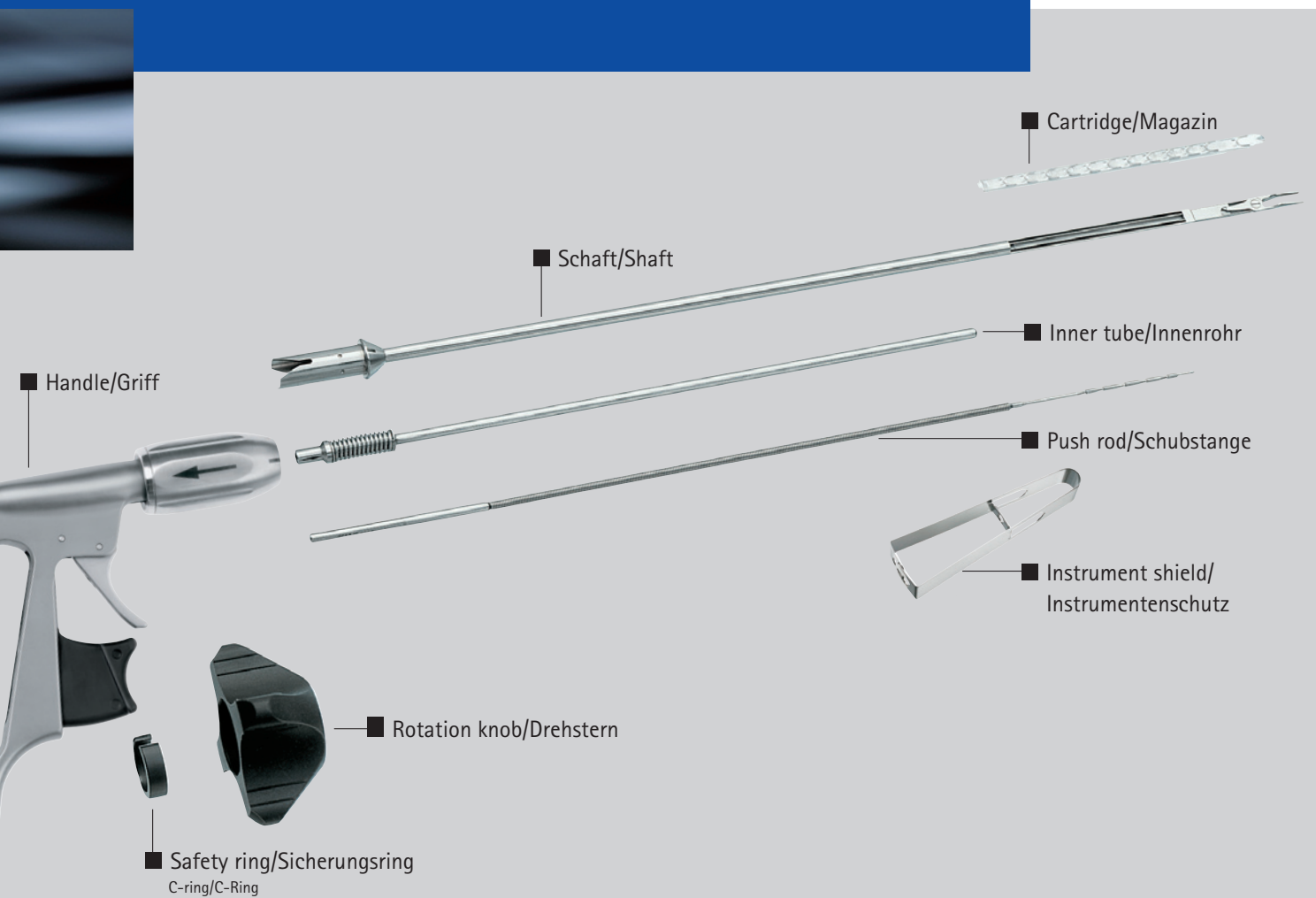

For care we recommend/Zur Pflege empfehlen wir

Instrument shield/
Instrumentenschutz

PL522/810

protects jaws during sterile preparation,
removal and processing
für Sicherheit während Sterilbereitstellung,
Entsorgung und Aufbereitung.

Ø/diam.
5 mm

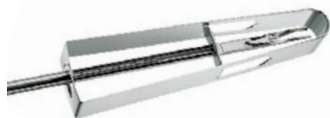

PL536/810

Protects jaws during sterile preparation,
removal and processing
für Sicherheit während Sterilbereitstellung,
Entsorgung und Aufbereitung.

Ø/diam.
10 mm

Oil spray/Ölspray

JG600

Sterilit i, Pack of 6 pcs. (not illustrated)
Sterilit i, Packung à 6 Stück (ohne Abb.)

Cleaning brush/Reinigungsbürstchen

GK469R

for inner tube diam. 5 mm, length 550 mm, pack of 6 pcs.
für Innenrohr Ø 5 mm, Länge 550 mm, Packung à 6 Stück



PM995R

for outer tube diam. 10 mm, length 550 mm, pack of 6 pcs.
für Außenrohr Ø 10 mm, Länge 550 mm, Packung à 6 Stück





AESCULAP®

B | BRAUN
SHARING EXPERTISE

Aesculap AG & Co. KG

Am Aesculap-Platz
78532 Tuttlingen
Germany

Phone +49 7461 95-0
Fax +49 7461 95-2600

www.aesculap.de

All rights reserved. Technical alterations are possible. This leaflet may be used for no other purposes than offering, buying and selling of our products. No part may be copied or reproduced in any form. In the case of misuse we retain the rights to recall our catalogues and pricelists and to take legal actions.